



OWNER'S GUIDE & INSTALLATION INSTRUCTIONS

In-Hull & Trolling Motor

Puck Transducer

Models: **P50, P72, P76, P78, P83**
CHIRP Model: **P155M**

03/15/16

17-010 rev.12

Follow the precautions below for optimal product performance and to reduce the risk of property damage, personal injury, and/or death.

WARNING: Always wear safety goggles, a dust mask, and ear plugs when installing.

CAUTION: Choose the transducer designed for your boat's deadrise angle. Never use adhesive to fill gaps between the transducer and the hull since this will greatly reduce the transducer's performance.

CAUTION: Fiberglass Hull—The hull must be SOLID fiberglass under the transducer. The transducer will not transmit through coring material such as foam or balsa wood.

CAUTION: CHIRP transducer—Do not install in the engine compartment or other hot place. The transducer may fail if it overheats.

CAUTION: Never pull, carry, or hold the transducer by the cable. This may sever internal connections.

CAUTION: Do not use adhesive to fill gaps between the transducer and the hull since this will greatly reduce the transducer's performance.

CAUTION: Never use solvents. Cleaner, fuel, sealant, paint, and other products may contain solvents that can damage plastic parts, especially the transducer's face.

IMPORTANT: Please read the instructions completely before proceeding with the installation. These instructions supersede any other instructions in your instrument manual if they differ.

Applications

- P50, P83, P155M for *aluminum* or fiberglass hulls
- P72, P76, P78 for fiberglass hulls *only*
- Aluminum hull must be less than 3.8mm (5/32") thick
- Recommended for high-speed boats
- P50, P72, P76, P83, and P155M accommodate a deadrise angle of 10° or less
- P78 accommodates a deadrise angle of 10° – 22°

Record the information found on the cable tag for future reference.

Part No. _____ Date _____ Frequency _____ kHz

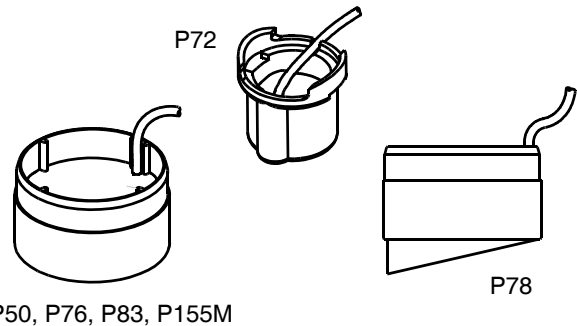

In-Hull Mount Tools & Materials

- Safety goggles
- Dust mask
- Ear plugs
- Duct tape
- Pole
- Detergent (some installations)
- Weak solvent (such as alcohol)
- Disk sander (some installations)
- Thin sealable plastic bags (some installations)
- Cable ties
- Water-based lubricant (such as K-Y® jelly) (some installations)
- Adhesive (see "Selecting the Adhesive" below)
- Paper cup (some installations)
- Stirrer (some installations)
- Sand (some installations)
- Grommet(s) (some installations)
- Installation in a cored fiberglass hull (see page 4):
 - Electric drill
 - Hole saw 78mm or 3"
 - Miniature disk sander (such as Dremel® rotary sander)
 - Repair epoxy (such as Pettit Flexpoxy 7076)

Selecting the Adhesive

CAUTION: Do not use:

- "5 minute" epoxies because they are too brittle.
- RTV (silicone) adhesives because they absorb most of the sound energy.

A hard adhesive transmit sound best. However, winter temperature extremes and flexing on trailer rollers can cause it to de-laminate. Soft adhesives absorb too much sound, so they will greatly reduce performance. To compromise, use a viscous slow-cure epoxy or a fairly rigid one-part adhesive sealant.

- **Aluminum hull**—Airmar recommends 3M® 4200, a polyurethane, marine, adhesive sealant.
- **Fiberglass hull**—Use the 2-part epoxy adhesive supplied with the P72, P76, and P78.

NOTE: In cold climates, a one-part polyurethane adhesive, such as Boat-Life's Life Seal®, may be best.

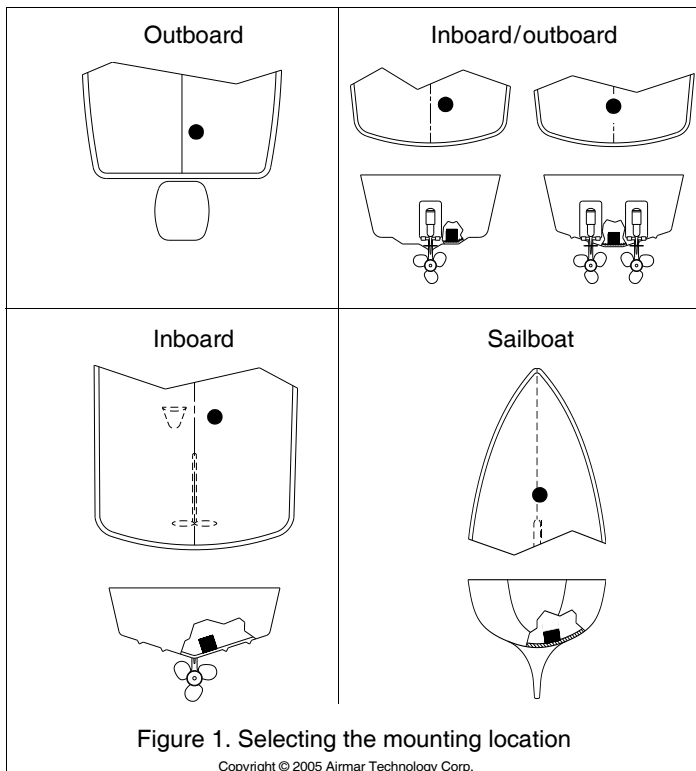

Figure 1. Selecting the mounting location

Copyright © 2005 Airmar Technology Corp.

Mounting Location

About Fiberglass Hulls

The fiberglass hull below the transducer must be solid. Since the hull absorbs acoustic energy, transmitting through the hull reduces the transducer's performance. Fiberglass hulls are often reinforced in places for added strength or to reduce weight. These cored areas contain balsa wood or structural foam which are poor sound conductors. **Do not locate the transducer over coring.**

Placement

CAUTION: Do not mount the transducer in line with or near water intake or discharge openings or behind strakes, fittings, or hull irregularities that will disturb the water flow.

Choose a location:

- Where the fiberglass is **SOLID** (no air bubbles are trapped in the fiberglass resin) and where no coring, flotation material, or dead air space is sandwiched between the inside skin and outer skin of the hull.
- Where the hull below the transducer will be in contact with the water at all times.
- Where the water flowing under the hull is smoothest with a minimum of bubbles and turbulence (especially at high speeds).
- Away from interference caused by power and radiation sources such as: the propeller(s) and shaft(s), other machinery, other echosounders, and other cables. The lower the noise level, the higher the echosounder gain setting that can be used.
- Where the transducer beam will not be blocked by the keel or propeller shaft(s).
- Where there is adequate space inside the vessel for the installation.
- **CHIRP transducer**—Mount in a cool well-ventilated area away from the engine to avoid overheating.

Boat Type (see Figure 1)

Consult the boat manufacturer for the best transducer placement. If this information is unavailable, follow the guidelines below.

When possible, mount on the side of the hull where the propeller blades are moving downward.

- **Outboard powerboats**—Install as far aft as is practical.
- **Inboard/outboard powerboats**—Install close to the engine(s).
- **Inboard powerboats**—Install forward of the propeller(s) and shaft(s).
- **Sailboats**—Install on or near the centerline and forward of any fin keel 300 - 600mm (1 - 2').

Testing the Selected Mounting Location

Establishing a Performance Baseline

The results of this test are used as a basis of comparison to determine the best in-hull location for the transducer.

1. Take the boat to the maximum depth in which you will be operating the echosounder. If deep water is not available, find a location with at least 15m (50').
2. Connect the transducer to the echosounder.
3. Tape the transducer to a pole, cable side up. *Do not tape over the active face.* Hold the transducer over the side of the boat with the active face fully submerged and parallel to the water surface (see Figure 2).
4. Observe the echosounder's performance and the gain setting required to obtain a reading on the display. Record the depth reading.

Testing the Location

While the boat is at the same site (depth of water), test the transducer inside the hull at the mounting location. Use one of the test methods below.

- A. For a location near the stern and a minimal deadrise angle**—Clean away any build-up of grease and/or dirt with detergent or alcohol. Place the transducer against the hull and allow bilge water to cover the surface where they touch (see Figure 3A).
- B. For a moderate deadrise angle**—If the hull surface is not smooth, grind it with a disc sander. Place the transducer inside a thin plastic bag. Partially fill the bag with water and close it tightly with a cable tie. Wet the surface of the hull and press the active face of the transducer against it through the bag (see Figure 3B).
- C. For any location**—If the hull surface is not smooth, grind it with a disc sander. Coat the face of the transducer with a **water-based** lubricant (such as K-Y® jelly). With a twisting motion, press the face against the hull (see Figure 3C) After testing, wipe all traces of the lubricant from the transducer's face.

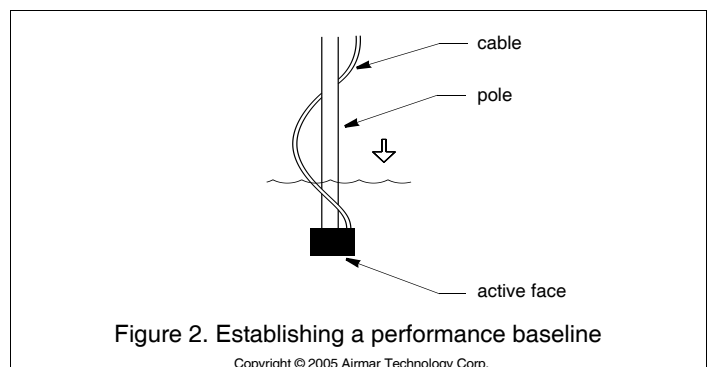

Figure 2. Establishing a performance baseline

Copyright © 2005 Airmar Technology Corp.

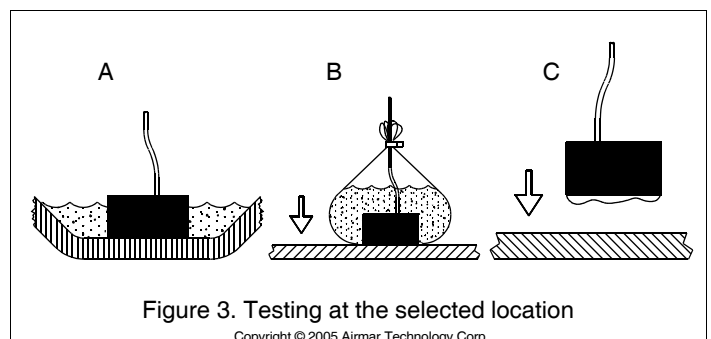

Figure 3. Testing at the selected location

Copyright © 2005 Airmar Technology Corp.

Observe the echosounder's performance and compare it to the baseline. Look for a stable depth reading that is similar to the baseline. Compare the thickness and intensity of the bottom trace.

If the performance is close to the baseline, this is a good mounting location. Remember, energy is lost transmitting through the hull. If the test reading differs markedly from the baseline, you will need to find another location to install the transducer.

NOTE: Fiberglass hull—If there is no reading or it is erratic, the transducer may be positioned over coring that is absorbing the acoustic energy. Choose another location. If no other spot is available, check with the boat manufacturer to be certain coring is present before proceeding with the instructions for "Installation in a Cored Fiberglass Hull" on page 4.

Installation

Cored fiberglass hull—Follow separate instructions on page 4.

CAUTION: Epoxy adhesive—Do not proceed if the hull temperature is below 15°C (60°F) because the cure time of the epoxy adhesive will be greatly extended.

1. The hull surface to be bonded must be flat, smooth, and free of paint or any other finish. If the surface is rough, use a disk sander to smooth an area 10cm (4") in diameter.
2. To ensure a tight bond, remove any dust, grease, or oil from the hull surface and the bottom of the transducer with detergent or a weak solvent such as alcohol. Dry both the selected area and the transducer.
3. Apply the recommended adhesive to the center of the transducer's active face—the flat side opposite the cable.

Aluminum hull—Airmar recommends 3M® 4200.

Fiberglass hull—If you are using a 2-part epoxy adhesive, be sure the *hull* temperature is above 15°C (60°F). Mix the epoxy until the color is uniform.

4. Press the transducer face onto the hull with a twisting motion to **expel all air bubbles**. Do not use adhesive to fill gaps (see Figure 4, 5, or 6). (If the hull is slanted, temporarily secure the transducer in place with duct tape.) The adhesive supplied by Airmar is cured in 24 hours at 21°C (70°F). The lower the temperature the longer the cure time.

Aluminum hull—Use a weight to hold the transducer in place until the adhesive cures. A small, sealable, plastic bag filled with sand works well.

Cable Routing & Connecting

CAUTION: If the transducer came with a connector, do not remove it to ease cable routing. If the cable must be cut and spliced, use Airmar's splash-proof Junction Box No. 33-035 and follow the instructions supplied. Removing the water-proof connector or cutting the cable, except when using a water-tight junction box, will void the transducer warranty.

1. Route the cable to the echosounder being careful not to tear the cable jacket when passing it through the bulkhead(s) and other parts of the boat. Use grommet(s) to prevent chafing. To reduce electrical interference, separate the transducer cable from other electrical wiring and the engine(s). Coil any excess cable and secure it in place with cable ties to prevent damage.
2. Refer to your echosounder owner's manual to connect the transducer to the instrument.

Installation in a Cored Fiberglass Hull

Installation in a cored hull is difficult. The objective is to bond the transducer to the **inside surface of the hull's outer skin** while preventing any moisture from penetrating the core.

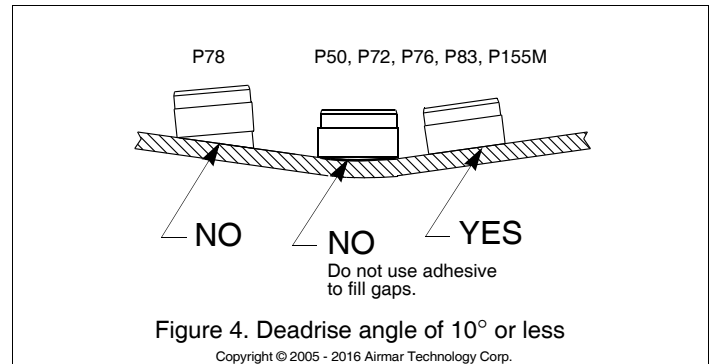

Figure 4. Deadrise angle of 10° or less

Copyright © 2005 - 2016 Airmar Technology Corp.

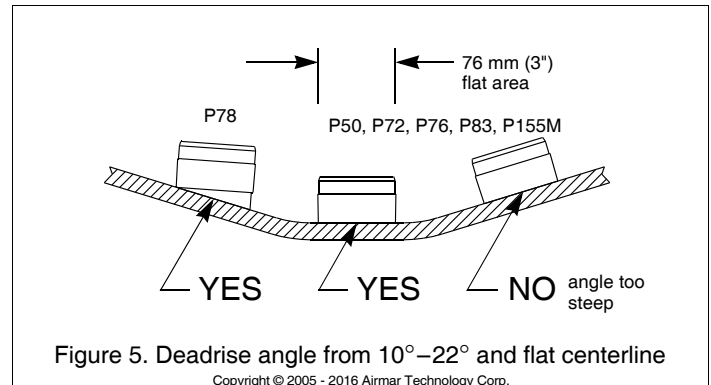

Figure 5. Deadrise angle from 10°–22° and flat centerline

Copyright © 2005 - 2016 Airmar Technology Corp.

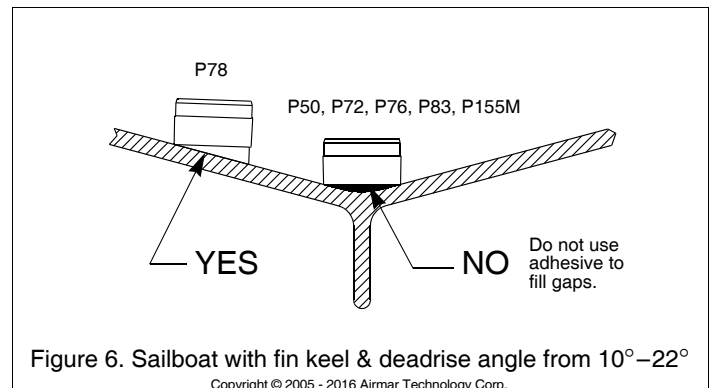

Figure 6. Sailboat with fin keel & deadrise angle from 10°–22°

Copyright © 2005 - 2016 Airmar Technology Corp.

CAUTION: There is no way to determine if the outer skin is solid (no trapped air bubbles in the fiberglass resin) at the selected location before cutting the inner skin.

CAUTION: Do not proceed if the hull temperature is below 15°C (60°F) because the cure time of the epoxy will be greatly extended.

1. Using a 78mm or 3" hole saw, cut through the *inner* skin and the core at the selected location (see Figure 7). The core material can be very soft. Apply only light pressure to the hole saw after cutting through the inner skin to avoid accidentally cutting the outer skin.
2. Remove the plug of core material so the inner core of the hull is fully exposed. Sand the *inside surface of the outer skin* using a miniature disk sander (Dremel® rotary tool). Slightly undercut the surrounding coring if possible.
3. Clean and dry both the *inside surface of the outer skin* and the face of the transducer with detergent or alcohol to remove any dust, grease, or oil.
4. Pour the epoxy adhesive into the cavity to a depth of 6mm (1/4") and **immediately set the transducer in place with a firm twisting motion to expel all air bubbles**. Do not use adhesive to fill gaps.

2-Part epoxy adhesive—Being sure the *hull* temperature is above 15°C (60°F), mix the epoxy until the color is uniform.

- Use about a half cup of *repair epoxy* following the manufacturer's directions. Fill the cavity around the transducer. *Avoid trapping air in the mixture.* Permit the *repair epoxy* to set for at least 1 hour. If the cavity is at an angle, as is usual, tape over the lower portion of the cavity. Add more epoxy and until the cavity is filled flush with the top of the inner skin. If the transducer is covered with repair epoxy, be sure the cable is bonded tightly so that no water seeps into the core.
- You may grind the surface smooth, if necessary, but do not damage the cable.
- If there is doubt as to the strength of the area, apply layers of fiberglass overall to a satisfactory thickness. Be sure bilge water cannot enter the core at the cable.

Trolling Motor Mount: P72 Applications

- Electric trolling motor with diameter from 77–95mm (3–3/4")
- Can be adapted for use with smaller or larger motor cases

Tools & Materials

Safety goggles
Band clamp (some installations)
Cable ties

Mounting Location

Locate the transducer under the motor case (see Figure 8).

NOTE: If the motor has a strut that shades the transducer, it will not significantly reduce the transducer's performance.

Installation

Small motor case [64mm (2-1/2")]: Do not to over tighten the band clamp causing the tabs on the transducer housing to break.

Large motor case [102mm (4")]: Purchase a larger stainless steel band clamp in the plumbing supply section of most hardware stores.

- Loosen the screw in the band clamp so that one end of the band is free.
- Wrap the band clamp around the motor case. Tighten the screw.

Cable Routing

CAUTION: Do not put tension to the cable as it exits the transducer, as excessive force can break internal connections.

CAUTION: On bow mounted motors, be sure the cable route does not result in pinching the cable when the motor is in the UP position.

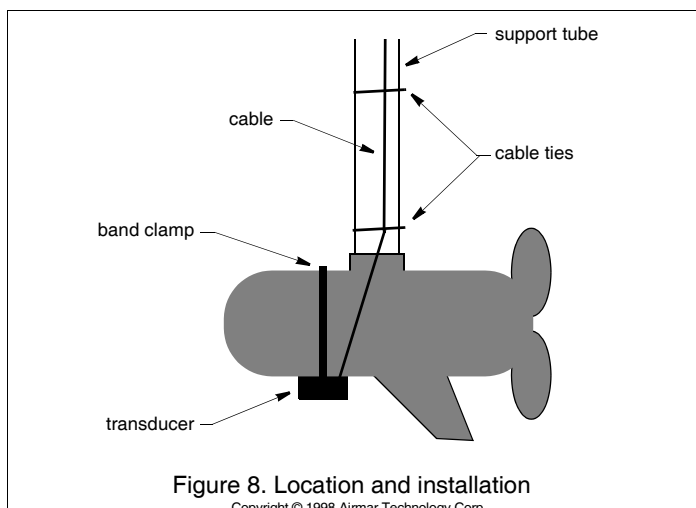

Figure 8. Location and installation

Copyright © 1998 Airmar Technology Corp.

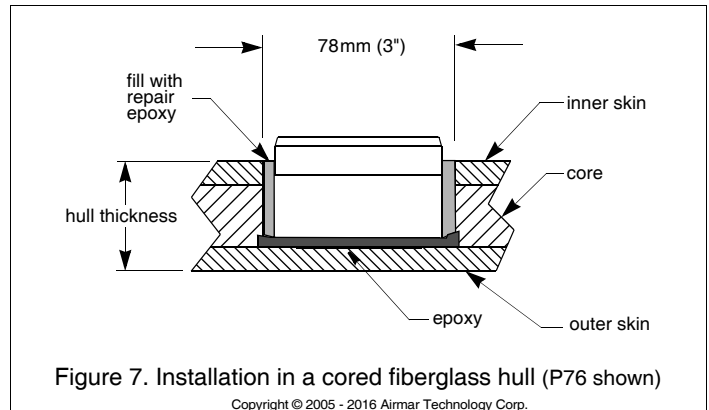

Figure 7. Installation in a cored fiberglass hull (P76 shown)

Copyright © 2005 - 2016 Airmar Technology Corp.

- Route the cable around the side of the motor case and along the support tube (see Figure 8).
- Secure the cable to the support tube with cable ties.
- Route the cable to the echosounder being careful not to tear the cable jacket. To reduce electrical interference, separate the transducer cable from other electrical wiring.
- To prevent damage, coil any excess cable and secure it in place with cable ties.

Maintenance & Repair

Cleaning

Keep the transducer free of marine growth and petroleum residue. To clean use a soft cloth and mild household detergent.

Damaged Cable Jacket

- Should the outer jacket of the cable be abraded or cut, check that the internal conductors are not damaged.
- If the conductors are damage free, allow the cable to dry and fill the damaged area with sealant.
- Cover the damaged area with electrical tape.

Severed Cable

- Slide heat-shrink tubing onto the cable.
- Splice each pair of matching colored conductors with rosin core solder.
- Wrap each conductor with insulating tape at the splice.
- Splice the shield (braided) wire with solder.
- Fill the spliced area in the cable with sealant.
- Cover the damaged area with the heat-shrink tubing and follow the manufacturer's directions for its use.

NOTE: If the instrument fails to provide a reading, the problem may not be the damaged cable; the transducer, connector or instrument could be defective.

Transducer Replacement

The information needed to order a replacement Airmar transducer is printed on the cable tag. Do not remove this tag. When ordering, specify the part number, date, and frequency in kHz. For con-venient reference, record this information at the top of page one.

Obtain parts from your instrument manufacturer or marine dealer.

Gemeco (USA)	Tel: 803-693-0777 Fax: 803-693-0477 email: sales@gemeco.com
Airmar EMEA (Europe, Middle East, Africa)	Tel: +33.(0)2.23.52.06.48 Fax: +33.(0)2.23.52.06.49 email: sales@airmar-emea.com