

GARMIN®

GSD™ 26

INSTALLATION INSTRUCTIONS

GSD 26 Installation Instructions

To obtain the best performance and to avoid damage to your boat, install the device according to these instructions.

Read all installation instructions before proceeding with the installation. If you experience difficulty during the installation, contact Garmin Product Support.

Important Safety Information

WARNING

See the *Important Safety and Product Information* guide in the product box for product warnings and other important information.

You are responsible for the safe and prudent operation of your vessel. Sonar is a tool that enhances your awareness of the water beneath your boat. It does not relieve you of the responsibility of observing the water around your boat as you navigate.

CAUTION

Failure to install and maintain this equipment in accordance with these instructions could result in damage or injury.

To avoid possible personal injury, always wear safety goggles, ear protection, and a dust mask when drilling, cutting, or sanding.

NOTICE

When drilling or cutting, always check what is on the opposite side of the surface to avoid damaging the vessel. This equipment should be installed by a qualified marine installer.

Transducers

A transducer is required to send and receive a sonar signal from the sounder. Proper transducer selection and installation are critical to the operation of the device. Because mounting locations vary, see your local Garmin dealer or contact Garmin Product Support for more information. Go to www.garmin.com/transducers to select a transducer.

Installation Preparation

NOTICE

For the best possible performance, the device must be installed according to these instructions. If you experience difficulty with the installation, contact Garmin Product Support.

Because every boat is different, you must carefully plan the GSD 26 sounder installation.

- 1 Select a mounting location.
- 2 Mount the sounder.
- 3 Connect the sounder to the Garmin Marine Network and to power.
- 4 Connect the sounder to the transducer.

Tools Needed

- Drill
- #8 (5 mm) drill bit for mounting surface
- #2 Phillips screwdriver
- 3 mm flat screwdriver
- Cable ties (optional)
- Dielectric grease
- Wire cutter
- Wire stripper
- 1 in. (24 mm) and ¹⁹/₃₂ in. (15 mm) wrenches
- Marine sealant (optional)

Mounting the Sounder

Mounting Location Considerations

- The sounder must be mounted in a location where it cannot be submerged.
- The sounder must be mounted in a location with adequate ventilation where it will not be exposed to extreme temperatures.
- The sounder should be mounted so that the LEDs are visible.
- The sounder should be mounted so that the power and network cables can be easily connected.
- The sounder should be mounted so that the transducer cable can be connected. If required, transducer extension cables are available through your Garmin dealer.

Mounting the GSD 26 Device

NOTICE

If you are mounting the device in fiberglass, when drilling the pilot holes, use a countersink bit to drill a clearance counterbore through only the top gel-coat layer. This will help to avoid cracking in the gel-coat layer when the screws are tightened.

NOTE: Screws are included with the device, but they may not be suitable for the mounting surface.

Before you mount the device, you must select a mounting location and determine what screws and other mounting hardware are needed for the surface.

- 1 Place the device in the mounting location and mark the location of the pilot holes.
- 2 Drill a pilot hole for one corner of the device.
- 3 Loosely fasten the device to the mounting surface with one corner and examine the other three pilot-hole marks.
- 4 Mark new pilot-hole locations if necessary, and remove the device from the mounting surface.
- 5 Drill the remaining pilot holes.
- 6 Secure the device to the mounting location.

Connecting the Sounder

WARNING

When connecting the power cable, do not remove the in-line fuse holder. To prevent the possibility of personal injury or product damage caused by fire or overheating, the appropriate fuse must be in place as indicated in the product specifications. Connecting the power cable without the appropriate fuse in place voids the product warranty.

NOTICE

Do not force a cable into its port. Forcing the cable can damage the pins. If the cable is properly aligned, the cable should connect easily.

Before you connect the sounder to the network, power, and the transducer, you must mount the sounder (*Mounting the Sounder, page 2*).

- 1 Route the cables using the appropriate tie wraps, fasteners, and sealant to secure the cables along the route and through any bulkheads or the deck.
- 2 Install the locking rings on the marine network and power cables (*Installing Locking Rings on the Cables, page 6*).
- 3 Connect the bare-wire end of the power cable to a 12 Vdc power source and to ground.
- 4 Apply dielectric grease to the end of the power cable.
- 5 Align the notch on the end of the power cable with the power port on the device, and press the cable into place.
- 6 Tighten the locking ring.
- 7 Repeat steps 5 and 6 for the network cable, and connect the device to a transducer (*Connecting the Device to a Transducer or Sensor, page 3*).
- 8 Select an option:
 - If your boat is equipped with a GMS 10 network port expander, connect the network cable to one of its available ports.
 - If your boat is not equipped with a GMS 10 network port expander, connect the network cable directly to the network port on your chartplotter.

Cable Routing Grommets

When routing cables through your boat, it may be necessary to drill holes to route the cables. Cable routing grommets can be used to cover cable installation holes. The grommets do not create a waterproof seal. If necessary, apply a marine sealant after installation to weatherproof around the grommet and the cable. You can purchase grommets from your Garmin dealer or directly from Garmin at www.garmin.com.

Connecting the Device to a Transducer or Sensor

NOTICE

You must install cord grip plugs in any unused cord grip to make sure water cannot enter the transducer wiring block area and damage the sounder.

The terminal blocks are not removable.

Preparing the Cable

- 1 Remove the terminal block lid from the sounder.
 - 2 Select an option:
 - Feed a sensor cable through the small cord grip ①, and pull the cable into the terminal block area.
 - Feed a transducer cable through one of the large cord grips ② on the housing, and pull the cable into the terminal block area.
- NOTE:** Do not tighten the cord grip.

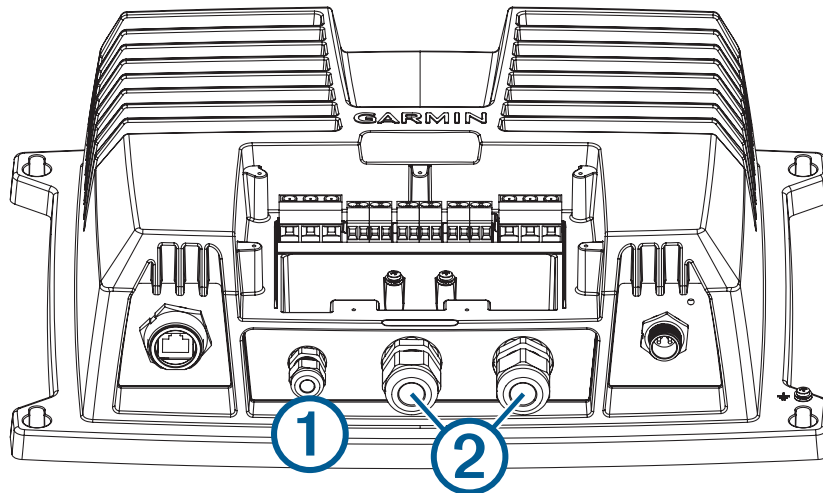

Connecting the Wires to the Terminal Block

Before you connect the wires, consult the wiring diagrams ([Transducer Wiring Diagrams, page 7](#)) to select the proper wiring configuration for your transducer and the wiring tables ([Transducer Wire Color Tables, page 9](#)) for specific examples of Garmin wire colors.

- 1 Connect the uninsulated section of each wire to the terminal block using a 3 mm flat screwdriver.
- 2 Connect the bare shield wire to one of the two ground posts under the terminal block using a #2 Phillips screwdriver.

Securing the Wire Connections

- 1 After connecting the wires, use a 24 mm (1 in.) wrench to tighten the nut around the transducer cable. When tightened correctly, you should not be able to pull the transducer cable out of the housing.
- 2 Insert a cord grip plug into each unused cord grip.
- 3 Replace and secure the terminal block lid on the sounder with a #2 Phillips screwdriver.

NOTE: The sounder does not operate when the lid is removed.

Grounding the Sounder

The chassis ground post is located on the exterior of the chassis, adjacent to a corner mounting hole.

- 1 Connect the chassis ground post to the boat water ground circuit.

NOTE: The boat battery ground is an acceptable alternative if your vessel does not have a designated water ground circuit.

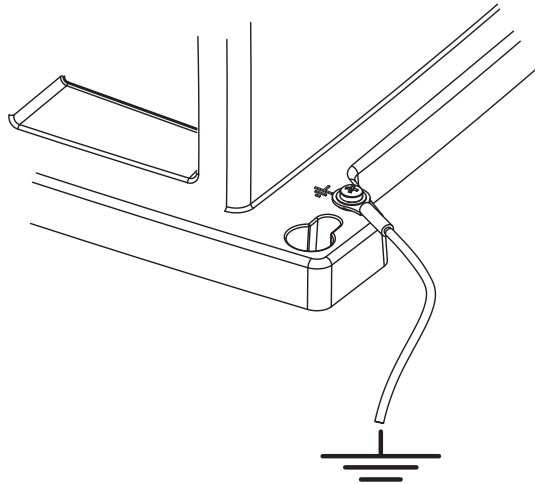

- 2 Mount the sounder ([Mounting the Sounder, page 2](#)) and connect the power, marine network, transducer, and sensors ([Connecting the Sounder, page 3](#)).

Manual Transducer Configuration

While most transducer models are detected and configured automatically, in some cases you may need to configure a transducer manually.

Manually Configuring a Transducer

- 1 From a sonar view, select **Options > Sonar Setup > Installation > Transducers**.
- 2 Select the GSD 26 sonar module.
- 3 Select **Manual Configuration**.
- 4 Select an option:
 - If you connected the transducer to the LOW FREQ XDCR terminals, select **Low**.
 - If you connected the transducer to the HIGH FREQ XDCR terminals, select **High**.
- 5 Select **Manual Enabled** to turn on manual configuration.
- 6 Set the parameters for your transducer ([Manual Transducer Configuration Parameters, page 6](#)).
- 7 Select **Done**.

Manual Transducer Configuration Parameters

NOTICE

If parameters are set incorrectly, manual transducer configuration may damage your transducer. If necessary, you should contact your transducer's manufacturer to verify the correct configuration parameters.

Impedance: The transducer's minimum impedance, in ohms.

Max. Transmit Power: The transducer's maximum transmit power, in watts.

Nominal Freq.: The transducer's nominal frequency, in kHz. If your transducer doesn't have a nominal frequency, set it to any frequency within its range. This will automatically set a frequency preset for this transducer.

CHIRP: Turn on if configuring a CHIRP transducer.

Lower 3dB Freq.: The lower frequency limit of CHIRP sweeps, in kHz.

Upper 3dB Freq.: The upper frequency limit of CHIRP sweeps, in kHz.

Manual Transducer Configuration Values

The following Garmin transducers require manual configuration for use with the GSD 26 sonar module.

Transducer Model	Impedance (Ω)	Max. Transmit Power (W)	Nominal Freq. (kHz)	CHIRP	Lower 3dB Freq. (kHz)	Upper 3dB Freq. (kHz)
GT12M-THF	80	350	125	On	85	165
GT15M-THF	80	600	125	On	85	165
GT17M-THF	100	1000	120	On	80	165

To obtain accurate manual configuration parameters for other transducers not produced by Garmin, contact the transducer's manufacturer.

Installing Locking Rings on the Cables

Before you install locking rings on the cables, you must route the cables.

To help make the cable-routing process easier, the locking rings are packaged separately from the cables. Each locking ring is packaged in a small bag with a number on the label for easy identification.

- 1 Separate the two halves of the locking ring ①.

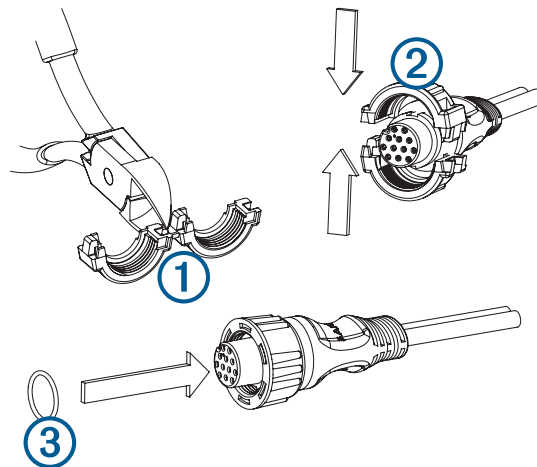

- 2 Align the two halves ② of the locking ring over the cable and snap them together.
- 3 Insert the o-ring ③ into the end of the connector.

Transducer Wiring Diagrams

NOTICE

Connecting the high-frequency wires to the low-frequency terminal block, or the low-frequency wires to the high-frequency terminal block, damages the device and the transducer.

You can use these diagrams to identify the connection points for your transducer wires on the GSD 26 terminal block. Locate your CHIRP/spread spectrum transducer model in the wiring color tables ([Transducer Wire Color Tables, page 9](#)) for more information.

The outer shield wire must connect to one of the two screw posts below the terminal block using the included ring crimp terminal.

TIP: The primary transducer cable wire housing covers the wiring bundles. To identify the wiring groups in the bundles more easily, you can remove up to an inch of the cable housing.

Single-Element CHIRP/Spread Spectrum

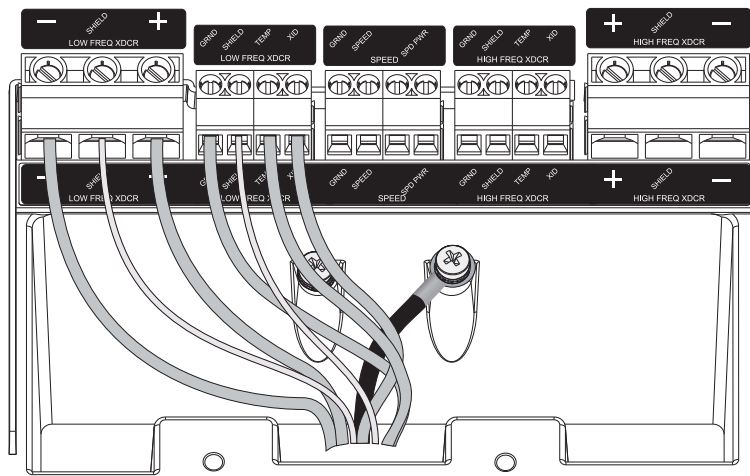

Dual-Element CHIRP/Spread Spectrum with Temperature and XID

NOTE: The temperature and XID wires can be connected at either location.

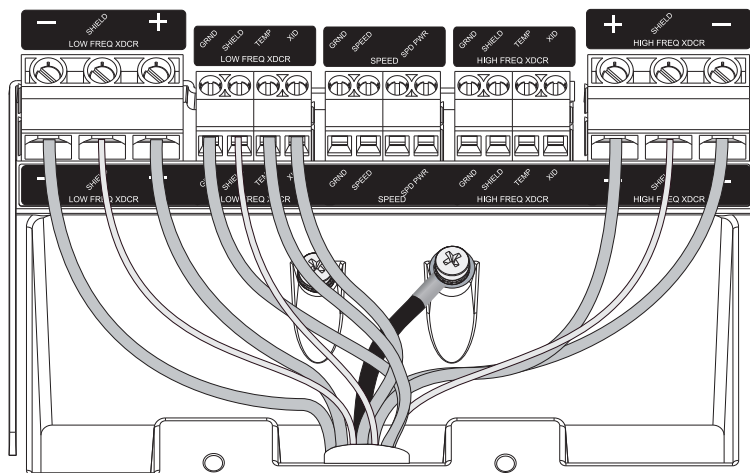

Dual-Element CHIRP/Spread Spectrum with XID

NOTE: The XID wires can be connected at either location.

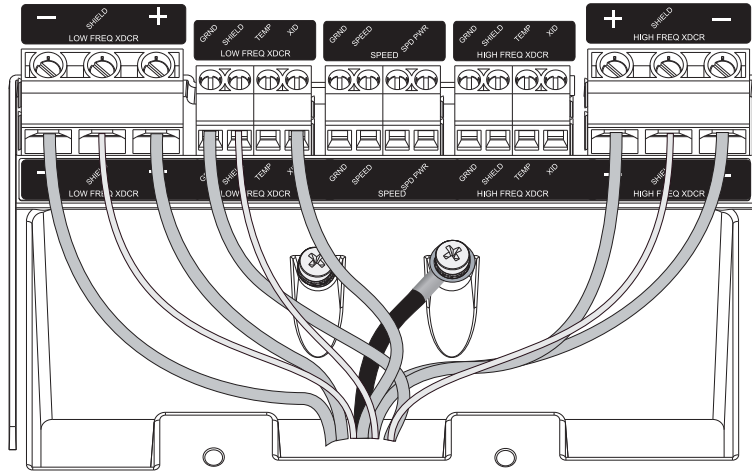

Dual-Element CHIRP/Spread Spectrum with Separate Temperature Sensor

NOTE: The temperature and XID wires can be connected at either location.

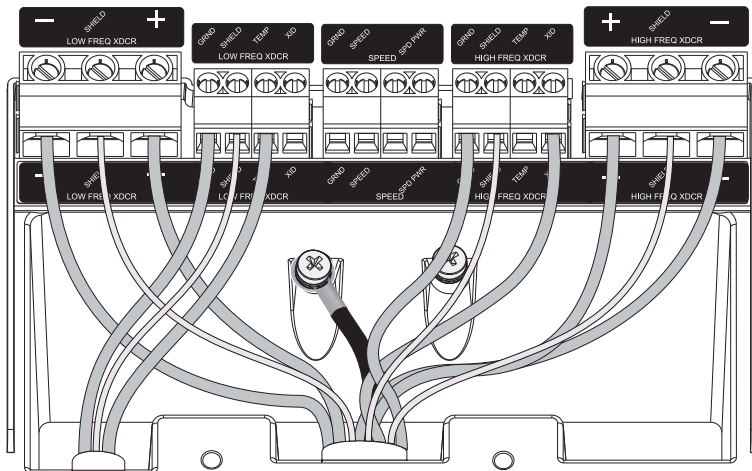

Dual-Element CHIRP/Spread Spectrum with Separate Speed Sensor

NOTE: The XID wires can be connected at either location.

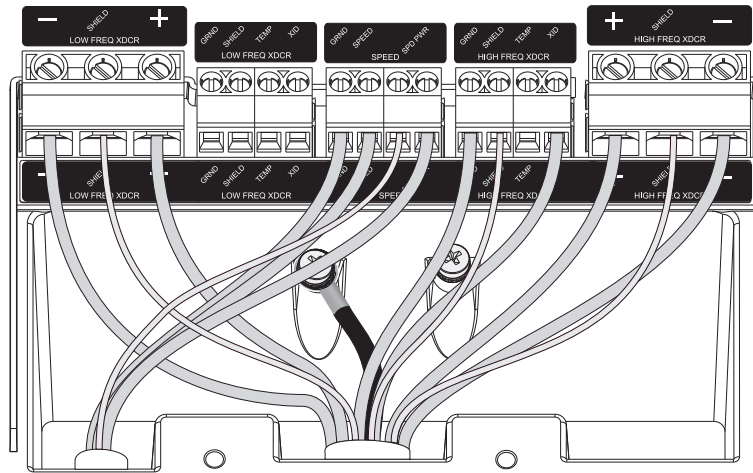

Transducer Wire Color Tables

You can use these tables to help identify wire functions on certain Garmin or Airmar transducers.

CHIRP/Spread Spectrum Transducers

Transducer Model	LOW FREQ XDCR +	LOW FREQ XDCR SHIELD	LOW FREQ XDCR -	GRND	SHIELD	TEMP	XID	HIGH FREQ XDCR +	HIGH FREQ XDCR SHIELD	HIGH FREQ XDCR -	Ground Post
Garmin GT12M-THF ¹	Red	NA	Black	Bare	NA	White	NA	Red	NA	Black	NA
Garmin GT15M-THF ¹	Red	NA	Black	Bare	NA	White	NA	Red	NA	Black	NA
Garmin GT17M-THF ¹	Red	NA	Black	Bare	NA	White	NA	Red	NA	Black	NA
Airmar R509LH	Blue/White ²	Bare	Black/White	Brown	Bare	White	Orange	Blue	Bare	Black	Bare
Airmar R509LM	Blue/White ²	Bare	Black/White	Brown	Bare	White	Orange	Blue	Bare	Black	Bare
Airmar R599LH	Blue/White ²	Bare	Black/White	Brown	Bare	NA	Orange	Blue	Bare	Black	Bare
Airmar R599LM	Blue/White ²	Bare	Black/White	Brown	Bare	NA	Orange	Blue	Bare	Black	Bare
Airmar R109LH	Blue/White ²	Bare	Black/White	Brown	Bare	White	Orange	Blue	Bare	Black	Bare
Airmar R109LHW	Blue/White ²	Bare	Black/White	Brown	Bare	White	Orange	Blue	Bare	Black	Bare
Airmar R111LH	Blue/White ²	Bare	Black/White	Brown	Bare	White	Orange	Blue	Bare	Black	Bare
Airmar M265LH	Blue/White ²	Bare	Black/White	Brown	NA	White	Orange	Blue	Bare	Black	Bare
Airmar B265LH	Blue/White ²	Bare	Black/White	Brown	NA	White	Orange	Blue	Bare	Black	Bare
Airmar TM265LH	Blue/White ²	Bare	Black/White	Brown	NA	White	Orange	Blue	Bare	Black	Bare
Airmar B265LM	Blue/White ²	Bare	Black/White	Brown	NA	White	Orange	Blue	Bare	Black	Bare
Airmar TM265LM	Blue/White ²	Bare	Black/White	Brown	NA	White	Orange	Blue	Bare	Black	Bare
Airmar B175H	NA	NA	NA	Brown	NA	White	Orange	Blue	Bare	Black	Bare
Airmar B175L	Blue/White	Bare	Black/White	Brown	NA	White	Orange	NA	NA	NA	Bare
Airmar B175M ³	Blue	NA	Black	Brown	NA	White	Orange	Blue	Bare	Black	Bare

¹ Can be connected to either LOW FREQ XDCR or HIGH FREQ XDCR terminal blocks. Requires manual configuration ([Manually Configuring a Transducer, page 5](#)). Tape off the bare end of the yellow wire.

² Yellow before 11/20/10

³ Can be connected to either LOW FREQ XDCR or HIGH FREQ XDCR terminal blocks.

Transducer Model	LOW FREQ XDCR +	LOW FREQ XDCR SHIELD	LOW FREQ XDCR -	GRND	SHIELD	TEMP	XID	HIGH FREQ XDCR +	HIGH FREQ XDCR SHIELD	HIGH FREQ XDCR -	Ground Post
Airmar PM265LH	Blue/White	Bare	Black/White	Brown	NA	White	Orange	Blue	Bare	Black	Bare
Airmar PM265LM	Blue/White	Bare	Black/White	Brown	NA	White	Orange	Blue	Bare	Black	Bare
Airmar PM411LWM	Blue/White	Bare	Black/White	Brown	NA	White	Orange	Blue	Bare	Black	Bare
Airmar B275LHW	Blue/White	Bare	Black/White	Brown	NA	White	Orange	Blue	Bare	Black	Bare
Airmar CM599LH	Blue/White	Bare	Black/White	Brown	Bare	White	Orange	Blue	Bare	Black	Bare
Airmar CM599LM	Blue/White	Bare	Black/White	Brown	Bare	White	Orange	Blue	Bare	Black	Bare
Airmar CM599LHW	Blue/White	Bare	Black/White	Brown	Bare	White	Orange	Blue	Bare	Black	Bare
Airmar TM150M ⁴	Blue	NA	Black	Brown	NA	White	Orange	Blue	NA	Black	Bare
Airmar B150M ⁴	Blue	NA	Black	Brown	NA	White	Orange	Blue	NA	Black	Bare
Airmar B75L	Blue/White	Bare	Black/White	Brown	NA	White	Orange	NA	NA	NA	Bare
Airmar B75M ⁴	Blue	Bare	Black	Brown	NA	White	Orange	Blue	Bare	Black	Bare
Airmar B75H	NA	NA	NA	Brown	NA	White	Orange	Blue	Bare	Black	Bare
Airmar 509LHW	Blue/White ⁵	Bare	Black/White	Brown	Bare	White	Orange	Blue	Bare	Black	Bare
Airmar TM185M ⁴	Blue	Bare	Black	Brown	NA	White	Orange	Blue	Bare	Black	Bare

⁴ Can be connected to either LOW FREQ XDCR or HIGH FREQ XDCR terminal blocks.

⁵ Yellow before 11/20/10

Blink Codes

After the sounder is installed, it turns on when the chartplotter is turned on. The two-color (green and red) status LED on the sounder indicates its operational status.

LED Color	State	Status
Green	Slow blink	The sounder is connected to a chartplotter and is operating properly. You should see sonar data on the chartplotter.
Red	Slow blink	The sounder is turned on, but is not connected to a chartplotter, or is waiting to connect to a chartplotter. If the sounder is connected to the chartplotter and this code persists, check the wiring connections.
Red/Green	Slow blink	The sounder is in test mode.
Red	Rapid blink sequence	System error. The chartplotter displays a message indicating the type of failure. When the error condition is fixed, the sounder must be completely disconnected from and reconnected to its power source to clear the error.

Specifications

Size	L x W x H: 274 x 373 x 100 mm (10.8 x 14.7 x 3.9 in.)
Weight	5.16 kg (11.37 lb.)
Case material	Fully gasketed, aluminum and steel housing with plastic access panel, water resistant to IEC 60529 IPX7.
Temperature range	From 5 to 158°F (from -15 to 70°C)
Power input	10–35 V
Power usage	100 W maximum
Fuse	10 A
Compass safe distance	60 cm (23.6 in.)
Sounder power	25-3,000 W (RMS)*
Frequency	25-250 kHz (dependent on transducer)
Depth	3,048 m (10,000 ft.)**
Data output	Garmin Marine Network

*Dependent on transducer rating and depth

**Maximum depth dependent on transducer, water salinity, bottom type, and other water conditions.

© 2014–2024 Garmin Ltd. or its subsidiaries

Garmin® and the Garmin logo are trademarks of Garmin Ltd. or its subsidiaries, registered in the USA and other countries. GSD and GMS™ are trademarks of Garmin Ltd. or its subsidiaries. These trademarks may not be used without the express permission of Garmin.

Airmar™ is a trademark of Airmar Technology Corporation.